

ASSEMBLY MANUAL

NINA SIDEBOARD



IMPORTANT INFORMATION BEFORE STARTING ASSEMBLY:

The assembly must be carried out by at least 2 people.

Do not place glass panes on unprotected hard surfaces, such as ceramic floors, iron, etc., as they may crack. Small gaps between the metal and the glass are normal, as they allow for the assembly of the piece!

ASSEMBLY KIT

- Assembly Manual QR Code;
- Handling and Cleaning Manual.
- Leveling foot.
- Silicone wedge

STEP BY STEP

1. Position the metal frame in the desired location. Level if necessary by rotating the leveling feet. Place the silicone shims as indicated in the adjacent figure.

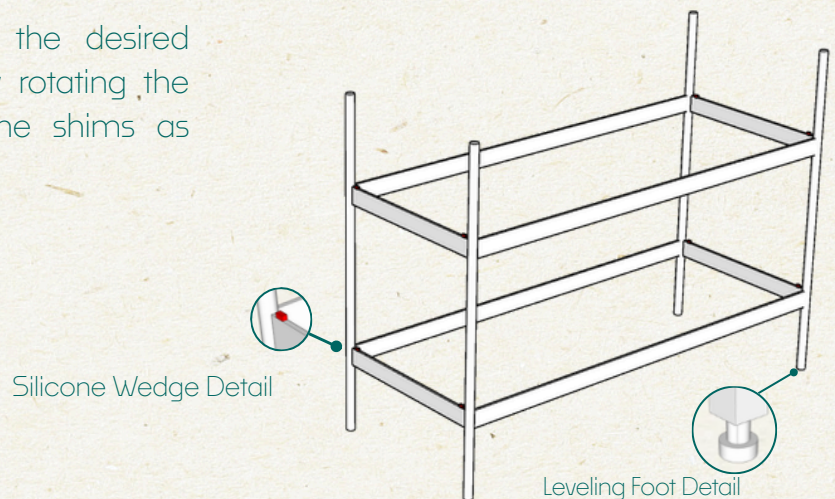

- 2.** First, fit the taller module into the lower niche along the side of the metal frame, centering it.

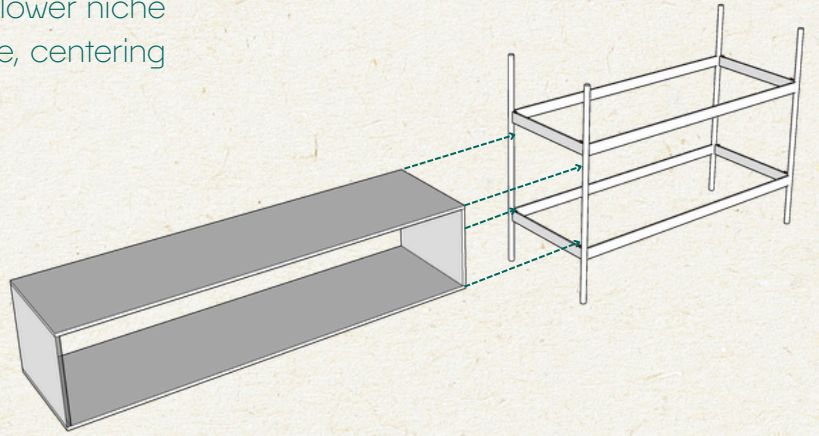

- 3.** Repeat the previous process for the small module, as shown in the image.

